



T

Therm



SL PUMP CONTROL SET INSTALLATION AND COMMISSIONING MANUAL

Single-Loop Underfloor Heating With
Thermostatic Mixing Valve

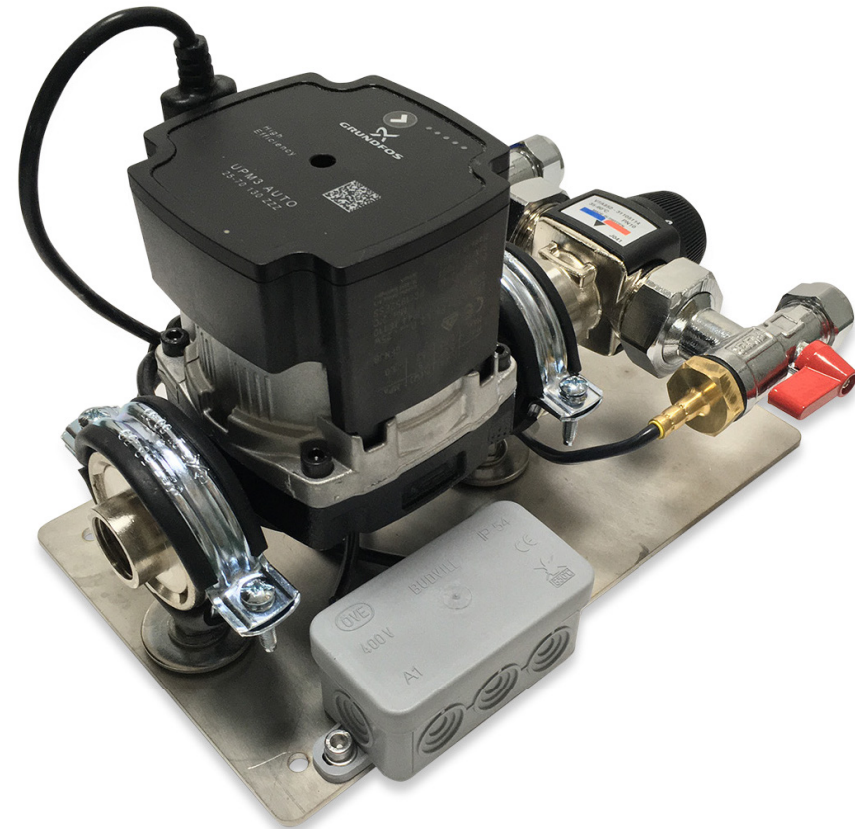

BOXED AND PRE-ASSEMBLED READY FOR INSTALLATION, INCLUDING:

- Thermostatic mixing valve adjustable from 35°C to 60°C
- Temperature switch for pump control on inlet water temperature - 40°C
- 'A' rated Grundfos UPM3 Auto pump
- ½" BSP female connection to underfloor flow and return
- Nickel plated for improved appearance
- In-built isolation valve in flow/return elbow
- 15mm compression connection flow and return
- TMV body kvs 1.3
- Mounted pump control terminal box

1. GENERAL

1.1 Provides control of flow and return water temperature in an underfloor heating system. Pre-assembled and tested to ensure that it can be fitted with minimum on-site labour required and commissioned immediately once fitted.

1.2 Designed to connect to new and existing heating systems with 15mm compression connections for the flow and return. The temperature switch supplies power to the pump and will remain open until the water temperature exceeds 40°C. Following this, the switch closes and activates the pump, which will allow the TMV to mix the flow and return to the required UFH temperature.

2. CONNECTIONS & DIMENSIONS

Item	Description	Qty
1	Therm 35-60 Thermostatic Mixing Valve	1
2	Isolation Ball Valve	2
3	½" BSP Female Adaptor	1
4	Temperature Switch 40°C	1
5	1" BSP X 1 ½" Flange Adaptor	1
6	1 ½" Pump Flange Nut	1
7	Grundfos UPM3 Auto Pump	1
8	½" BSP Female Adaptor	1
9	½" Compression Connections	1
10	Junction Box	1

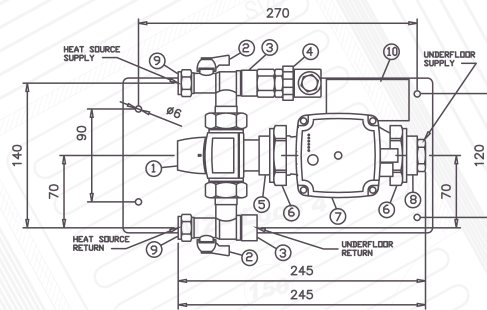

3. TECHNICAL DATA

T4 Pump Control	
Maximum static pressure	10 Bar
Maximum differential pressure	3 Bar
Maximum temperature	95°C
Operating temperature range	Adjustable between 35°C to 60°C
Inlet connections	15mm compression
Outlet connections	1 ½" BSP FEMALE
Temperature switch	40°C
KVs	1.6
Material	Nickel plated brass
Power	230V

4. PRE-INSTALLATION

4.1 Carefully remove from the packaging and check that all components are in place and that nothing has been damaged during delivery.

4.2 Supplied for connection with return to the left-hand side but can be altered easily for connection to the right-hand side.

4.3 To change orientation:

- Using an appropriate spanner, loosen the rotating flange nut securing the mixed outlet of the TMV to the pump inlet.
- The upper assembly can then be rotated through 180°, reversing the connections. Care should be taken not to over stretch the cable connection to the temperature switch.
- Re-tighten pump flange nut.

4.4 The pump mixer can be attached to the heating system. Using the dimensions shown in Fig. 1, ensure that there is enough available space for installation and maintenance at the intended position.

5. INSTALLATION

5.1 Filling the UFH system: The TMV is set to allow the return flow port to be partly open at all times. Therefore, care should be taken to ensure the UFH is fully filled and does not bypass through the TMV.

5.2 The pump mixer and underfloor circuits can now be filled and commissioned in accordance with the manifold instructions. Prior to filling, a final check of all joints should be made to ensure no connections have loosened during transit.

5.3 Ensure that the pump is filled and vented. Operate the control system to call for heat and select the desired pump setting.

5.4 Wiring should be carried out by a competent electrician using the wiring diagram in Fig. 2 on the following page.

5.5 Flow temperature can be adjusted using the dial on the ESBE TMV (35-60°C).

Setting Number	1	2	3	4	5	6
Temperature (°C)	35	40	45	50	55	60

Warning

Thread sealed joints should not be rotated as this will break the seal and invalidate the warranty.

6. WIRING

A 3 Amp mains-fused spur is required for the electrical wiring. The pump pack automatically detects radiator or mains heating circuit activity using an in-built temperature control switch.

6.1 Use the junction box included to wire your thermostat and fused spur.

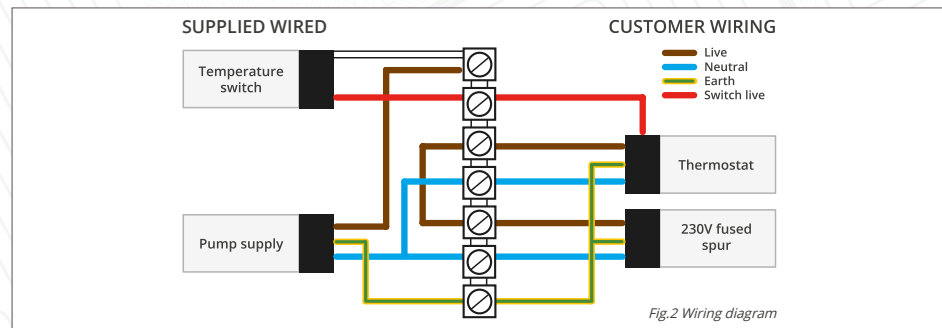

7. PUMP CONTROL MODES & FUNCTIONS

The user interface is designed with a single push button, one red/green LED and four yellow LEDs.

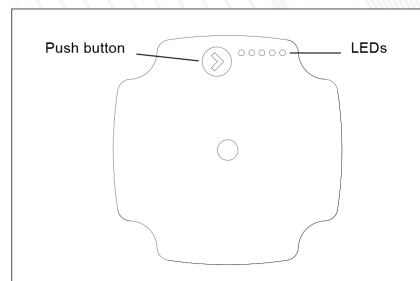

The User Interface shows:

- Performance view (during operation)
 - Operation status
 - Alarm status
- Settings view (after pressing the button)

During operation, the display shows the performance view. If you press the button, the user interface switches the view or runs in the setting selection mode.

Alarm Status

If the circulator has detected one or more alarms, the bi-colored LED 1 switches from green to red. When an alarm is active, the LEDs indicate the alarm type as defined in the table below. If multiple alarms are active at the same time, the LEDs only show the error with the highest priority. The priority is defined by the sequence of the table. When there is no longer an active alarm, the user interface switches back to operation mode.

Display	Indication	Pump Operation	Counter Action
One red LED + one yellow LED (LED 5)	Rotor is blocked	Trying to start again every 1.33 seconds	Wait or unblock the shaft
One red LED + one yellow LED (LED 4)	Supply voltage too low	Only warning, pump runs	Control the supply voltage
One red LED + one yellow LED (LED 3)	Electrical error	Pump is stopped because of low supply voltage or serious failure	Control the supply voltage / Exchange the pump

Performance View

The performance view shows either the operation status or the alarm status.

Operation Status

When the circulator is running, LED 1 is green. The four yellow LEDs indicate the current power consumption (P1) as shown in the table below. When the operation mode is active, all active LEDs are constantly on in order to differentiate this mode from the select setting mode. If the circulator is stopped by an external signal, LED 1 flashes green.

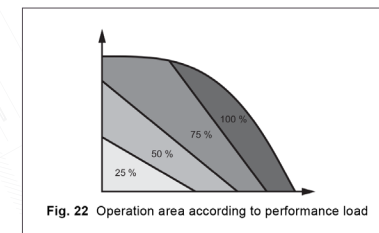

Display	Indication	Performance in % of P1 MAX
One green LED (flashing)	Standby (only externally controlled)	0
One green LED + one yellow LED	Low performance	0-25
One green LED + two yellow LED	Medium low performance	25-50
One green LED + three yellow LED	Medium high performance	50-75
One green LED + four yellow LED	High performance	75-100

